

(2:441)

APPLICATIONS

N trucks are used primarily for transport operations where the goods which are being carried have a high weight per unit volume or when length regulations do not have a negative effect on the payload. When trucks are required to operate mainly on bad roads, the simpler design of the N truck contributes to maintaining a high level of operational reliability. If the driver has to continually get into and out of the vehicle during his normal working day, the convenient entry/exit facility on the N truck is a definite advantage. When an unladen truck is driven on slippery surfaces, an N truck has better manoeuvrability than an F truck. This is due to the fact that the chassis weight of the N truck is distributed in such a way that more weight is placed on the driving wheels. N trucks are used primarily for construction site work, tanker transport, and as tractor units for semi-trailers. N trucks are often used for special superstructures or vehicles of the all-round type.

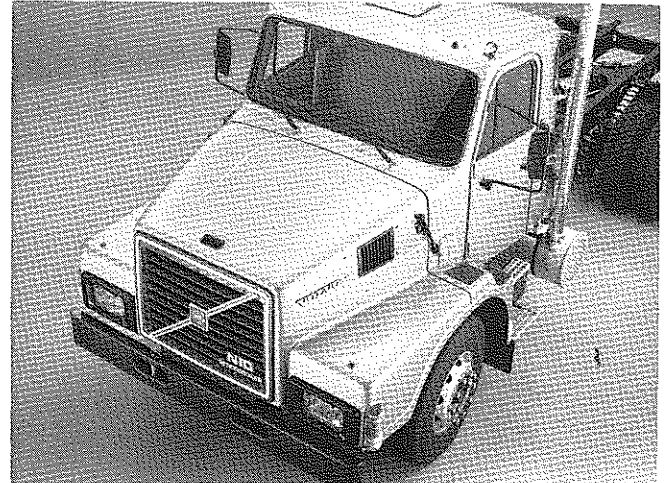

DESCRIPTION

Exterior: The cab has smooth styling features with a small frontal area that gives low air drag and lower fuel consumption. Cab dimensions have been chosen to maintain an exceptionally good balance between the demands for a large load area and a spacious cab. At the same time, the engine must be easily accessible for servicing. The result is a relatively short cab which, through its exceptionally well-planned layout, provides the driver with a comfortable and effective workplace. The distance from the bumper to the rear wall of the cab (BBC) is 245 cm, which is a good compromise for this type of truck. This is a relatively short BBC dimension compared with that of competitors' trucks. This means that shorter wheelbases can be used or larger load areas obtained. The bonnet tips forward

and makes the entire front end of the vehicle accessible, thus facilitating servicing. The bonnet also has new external bonnet locks and rubber-dampened contact against the cab.

Materials: The cab is made of steel. Its design is similar to that of earlier Volvo safety cabs. It is of an all-welded construction with sheet steel on a frame made up of steel profiles. The bonnet and mudguards are made of galvanized sheet steel (on certain markets these are made of GRP plastic).

Features	Benefits
<ul style="list-style-type: none"> ● Short BBC dimension (bumper to back of cab). ● All-steel cab, impact-tested. 	<ul style="list-style-type: none"> ● Short wheelbase, large load area. ● Robust all-welded steel cab for high level of operational reliability when operating in difficult conditions.
<ul style="list-style-type: none"> ● Wide, anti-slip exit/entry step of "staircase" type. ● Electronic speedometer and tachograph. 	<ul style="list-style-type: none"> ● Convenient entry/exit facility. ● Operationally reliable, long service life. No interference with other instruments. Easy and fast calibration. Less costs for standstill.
<ul style="list-style-type: none"> ● Volvo-designed seat programme featuring <ul style="list-style-type: none"> - Dished seat and backrest - All controls located on one side - Full range of adjustments on seats, backrest, head restraint and suspension - Air-suspended seat with special lumbar support. 	<ul style="list-style-type: none"> ● - Good lateral support even when the truck rolls and sways - Simplified handling of controls - Seating comfort to suit any size, shape or weight - Exclusive seating comfort.
<ul style="list-style-type: none"> ● Well-insulated, dense bitumen material. ● Large windows, sloping bonnet. ● Unique surface treatment process with 3 coats. 	<ul style="list-style-type: none"> ● Low noise level. ● Excellent close-up and all-round visibility. ● High level of quality of resistance to corrosion and durable finish.
<ul style="list-style-type: none"> ● Electrical distribution unit located inside the cab. 	<ul style="list-style-type: none"> ● Protected position. Easily accessible. Easy to service.

N10/12 Cab

Safety cab: The cab complies with the Swedish safety requirements—which are among the most severe in the world—by a wide margin. These requirements specify that the cab roof must withstand a load that is twice the unladen weight, and that the cab must also withstand impact against the windscreen pillars and the rear wall with a force of 29,500 Nm (3,000 kpm). The test is performed by means of a 1-tonne pendulum with a drop of 3 metres. The demand is that the cab must not be deformed to such an extent that it encroaches on the driver's survival space, and that the doors remain closed. Since the engine, bonnet, wheels and axles etc. are located in front of the driver, the driver is safer in an N truck than in an F truck. Inertia reel seat belts can be fitted for the driver and passenger. All interior fitting materials used for upholstery, mats, dashboard and cab trim are fire retardant, and comply with FMVSS 302, the tough American legislative requirements.

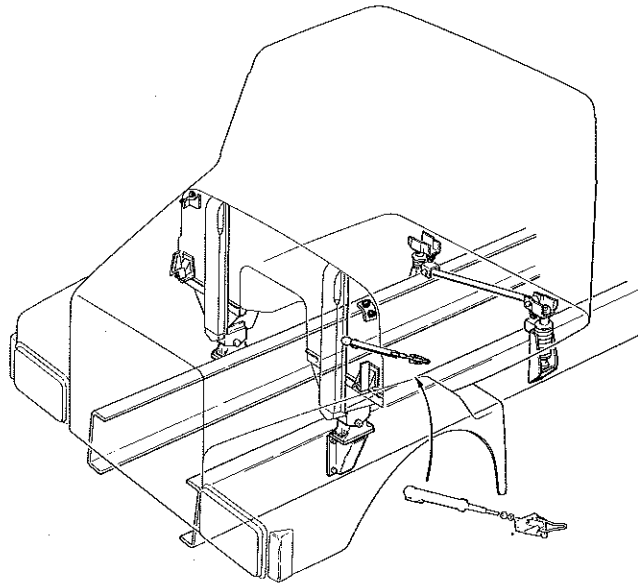

Cab mountings: The cab has two rubber journalled mountings at the front and two coil springs at the rear. Two shock absorbers are fitted to stabilize the cab. Lateral movement of the cab is absorbed by a cross stay fitted between the cab and the chassis frame. This system means that the cab is well insulated from frame vibrations and road shock.

Entry: Two wide and robust anti-slip steps formed like a "staircase" provide access into the cab. This simplifies exit as well, since you can easily see where to put your feet. Grab handles, one fitted on the outside of the cab behind the door and one inside the cab, facilitate entry and exit even more. Refer to the dimension sketch for the size of the entry steps.

Interior: The cab interior is very well planned and spacious, and provides exceptionally good driving comfort, particularly with regard to the fact that the cab is relatively short.

Seats: The driver's seat is fully sprung and has a long dished backrest for lateral support. The seat cushion is also dished for good support even when the truck rolls and sways. The seat is provided with a wide range of adjustments. This means that the driver has every chance of adapting the seat to suit his own particular requirements. The adjustment range fore-aft is 150 mm. The seat springs can be adjusted to suit the weight of the driver. Adjustment range 40–130 kg. Backrest inclination can also be adjusted, as well as the height and inclination of the seat cushion. Adjustment range: 65 mm through 7 positions for both the front and the rear edge of the seat. All controls are fitted on the side of the seat nearest to the door.

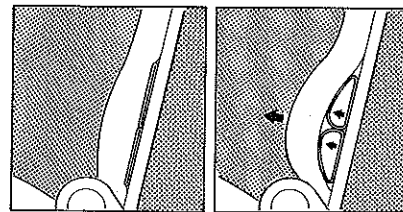
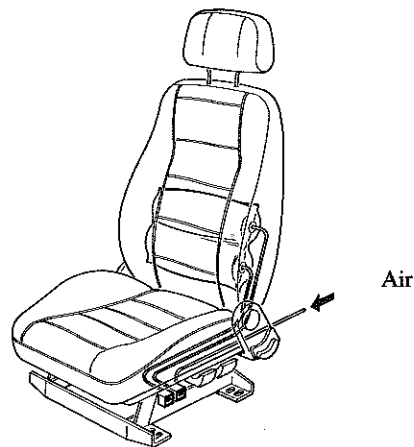

An air suspension seat is available when even better sitting comfort is required. This seat has an air suspension system that automatically adjusts to the driver's weight to give the smoothest possible ride. The seat takes about 10–15 seconds to adjust itself. When there is no weight or load on the seat, the seat is about 4 cm lower than when loaded. This gives more space

between the seat and steering wheel for easier access into the cab. This ergonomically-designed seat also incorporates an adjustable lumbar support consisting of two air-filled pads in the lower region. With the help of the lumbar support the driver can adjust the seat to suit his own personal requirements.

Controls and instruments: The steering wheel can be set to various positions and moved fore-aft (range 20°) and up-down (40 mm). The instrument panel is divided into three units that can be removed separately. The control lamps and instruments are grouped and located in the centre in front of the driver. To the left are the heater controls, and to the right the switches. The panel is prepared for the installation of extra switches and a radio.

There are three stalks on the steering column. To the left is the stalk for the windscreen wipers and washers, and a stalk for turn indicators, light switch, and headlight flasher. The stalk on the right regulates the trailer brakes.

The following controls and functions are grouped between the driver's seat and passenger bench seat. See figure. The engine is started by means of a key.

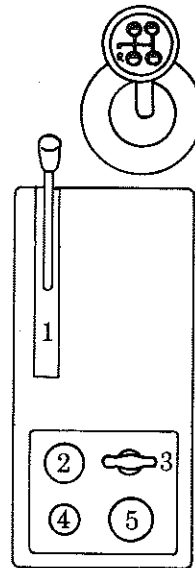

1. Parking brake
2. Blocking valve for parking circuit
3. Stop control
4. Hand throttle
5. Tyre inflation valve

Key to symbols

1. Warning, standard alternator charge
2. Warning, extra alternator charge
3. Spare
4. Warning for low oil pressure in engine
5. Warning for high coolant temperature or low coolant level
6. Warning for low air pressure in service brake system
7. Warning, parking brake applied or low air pressure in parking brake circuit
8. Control, splitter (overdrive)
9. Control, turn indicators
10. Control, turn indicators, trailer
11. Control, bogie lift in end position (or Robson drive engaged)
12. Control, main beam on
13. Control, electric starting heater on, pre- or post-heating on
14. Control, engine air cleaner clogged
15. Control, differential lock between driven wheels engaged
16. Control, differential lock between axles engaged (6×4 models)

Control lamps and warning lamps:

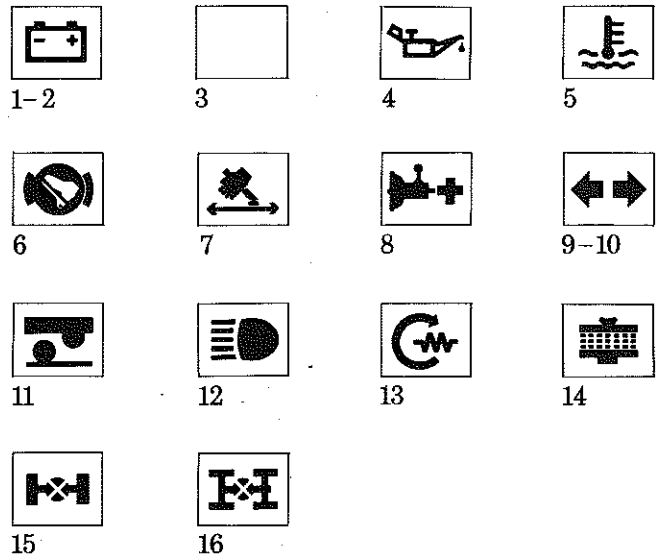

Checking bulbs: Control lamps 8—oil temperature MR62 and 14—engine air cleaner normally never light up. For this reason you should check the function of the bulbs themselves by switching on the master key without starting the engine, and then these bulbs should also light up.

Buzzer: The following warning lamps and control lamps are combined with a buzzer: 4, 5, 6, 15 and 16.

N10/12 Cab

Symbols for switches

17. Hazard warning flashers
18. Parking lights and instrument lighting
19. Electrically-heated rear view mirrors
20. Windscreen wipers and washers
21. Intermittent windscreen wiper operation
22. Exhaust pressure governor
23. Main beams/spotlights
24. Fog lamps, front
25. Fog lamps, rear
26. Bogie lift
27. Turn indicators
28. Power take-off, side
29. Power take-off, rear
30. Differential lock between axles
31. Differential lock between wheels
32. Loading lamp, fifth wheel coupling
33. Tipper, tractor unit
34. Tipper, side
35. Tipper, trailer
36. Side board release, right
37. Side board release, left
38. Tailboard release
39. Rotating warning lamp
40. Sanding equipment
41. Robson drive
42. Crane
43. Tail lift
44. Diagonal snow plough, angle setting
45. Front-mounted snow plough, vertical adjustment
46. Cab roof sign lighting



17

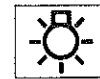

18



19



20



21

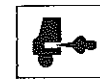

22



23



24



25



26

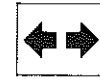

27



28



29



30



31



32



33



34



35



36



37



38



39



40



41



42



43



44



45



46

The speedometer and tachograph are electronic units. This totally eliminates the problems related to mechanical systems that require cables and adapters. Cable failure, noise transmitted from the gearbox to the instrument panel etc., are all things of the past. The much improved reliability means a longer service life on a par with that of the other components in the vehicle. If the tyre size or final drive ratio are altered, the system is quickly and easily recalibrated in the cab by means of a special instrument. The complete system consists of a speedometer and/or a tachograph, cable and a sensor on the gearbox. The sensor measures the wheel speed by picking up pulses from the output shaft which are proportional to the engine speed. The pulses are processed in the black box which controls the speedometer, odometer, and the tachograph needle.

The electrical distribution unit is located inside the cab for protection and easy access behind and beneath the locker. The circuit board drops down to provide access when servicing. The relay board is reached by lifting out the locker. The fuses are of the porcelain type and are easy to fit.

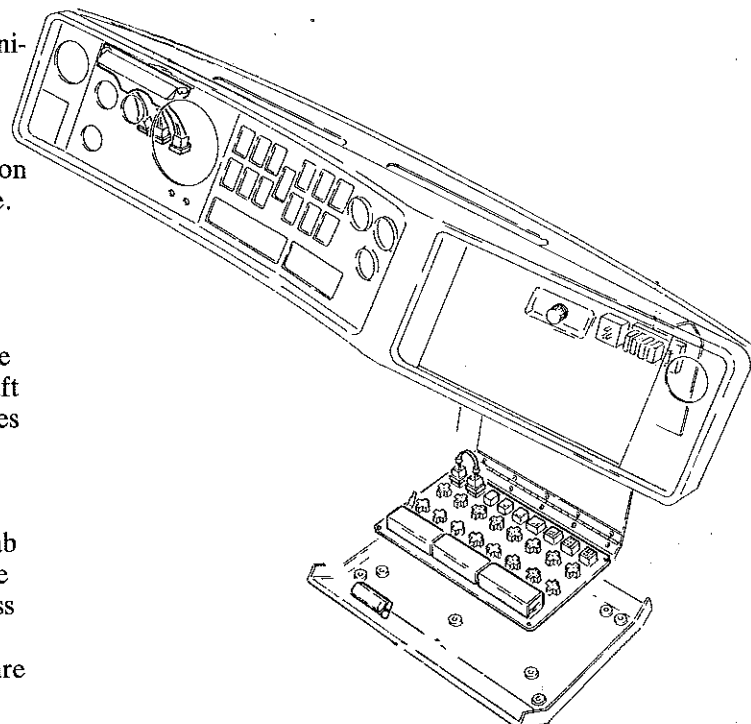

Heating and ventilation: The heating and ventilation controls are easily accessible to the left of the steering wheel. The symbols are grouped on the right-hand side of the panel.

The incoming air is cleaned efficiently by means of a special paper insert filter with an area of 0.5 m². This is of importance to people suffering from allergies, since the filter traps both dust and pollen. The filter shall be cleaned once a month and replaced once a year.

The warm air is distributed effectively throughout the entire cab thanks to the through-flow ventilation. Air is admitted through the defroster nozzles, adjustable nozzles in the instrument panel, and entry points at the floor.

When the air has passed through the cab, it leaves through openings at the bottom in both rear corners of the cab. Heater capacity and air circulation are so efficient that it is possible to maintain a steady temperature of +35° C inside the cab when the temperature outside is -20° C.

There are fresh air intakes on both sides of the cowl, which provide ample through-flow of air. A roof hatch is standard.

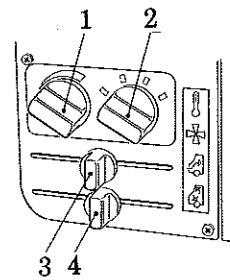

1. Temperature
2. Fan
3. Air volume
4. Air distribution, windscreen—
floor

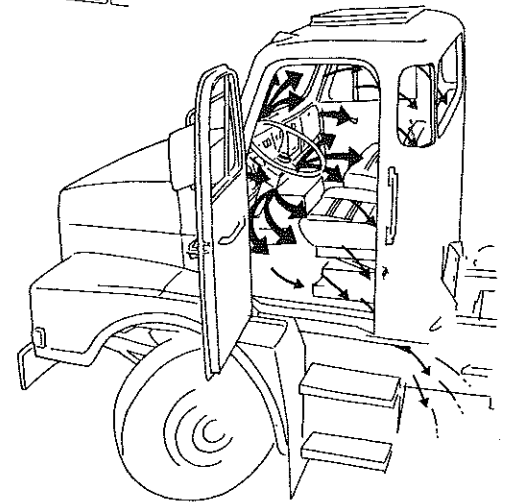

Visibility: N trucks are often used in confined spaces and in city traffic, thus making close-up and all-round visibility particularly important. The large corner windows are particularly convenient when the truck is being reversed. The sloping engine bonnet means that close-up visibility is excellent. All-round visibility is also exceptionally good (see figure). Two large rear view mirrors contribute to better visibility for the driver.

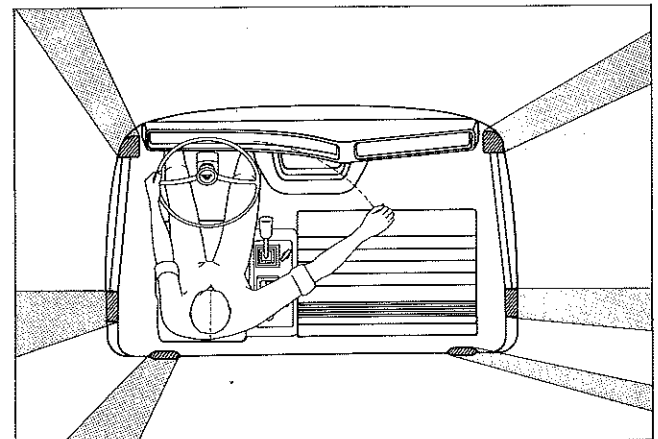

Noise insulation: The cab is well insulated against noise by means of 7 kg/m² bitumen material glued to the floor. The cowl panel has a moulded cover of 8 kg/m² high density material and 10 mm thick foam plastic. The bodywork openings for the accelerator pedal and steering column are sealed with rubber grommets. The gear lever is insulated by means of a rubber bellows, a felt sleeve, and a plastic protector. The engine casing is made of insulated sheet metal and is screwed securely to the cab floor, thus effectively preventing any noise and heat from penetrating into the cab. The suspended accelerator pedal also contributes to a lower noise level.

The in-cab noise level during acceleration at 80 km/hour in top gear is 75—76 dB(A).

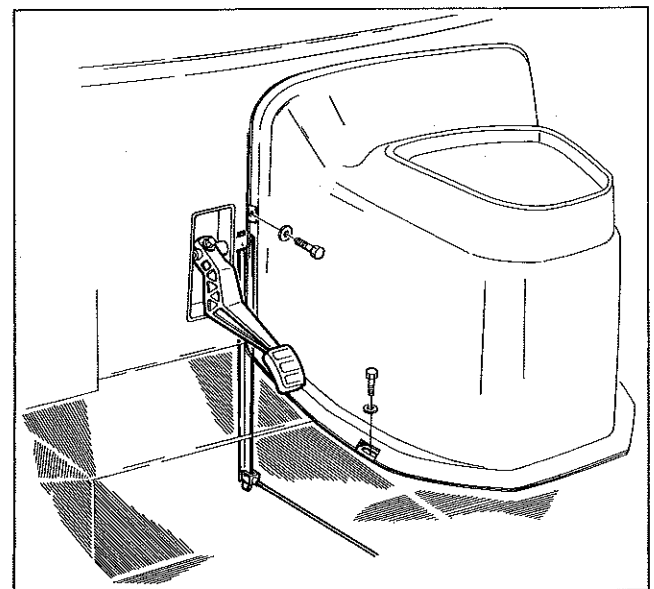

N10/12 Cab

Surface treatment

The bonnet and mudguards are made of galvanized sheet steel (some markets have GRP). The galvanizing process gives a zinc oxide coating that protects the entire surface of the sheet metal against corrosion, including the edges. The zinc oxide coating has a self-healing capacity, migrating from the sides of any scratches to heal over the damage. It also gives excellent rustproofing of welded joints.

The painting process is started by a unique combination of three different **pre-cleaning methods**: Alkalic dip degreasing, brush and spray emulsion degreasing, alkalic spray degreasing. This very thorough cleaning process with subsequent **zinc phosphatization** gives stronger protection against the effects of corrosion such as caused by flying stones or scratches in the paint-work, and also gives a good foundation for the following coats of paint.

Coating no. 1 (EC primer) is applied in a cathodic electro-dip plant. This method, which is entirely superior to previous (anodic) methods gives, above all, better penetration of the paint into body members and cavities.

Coating no. 2 consists of a special corrosion-resistant spray surfacer that is applied in a heated airless electrostatic process, which results in a thicker coating than achieved with conventional spraying methods.

Coating no. 3 is a high-gloss top coat.

Underbody treatment consists of a tixotropic rustproofing fluid. The tenacious adhesion and flexible consistency of this rust-inhibiting fluid means that any damage or scratches in the surface are healed over. Rustproofing treatment of body members, cavities and joints is provided by a penetrating rust inhibiting fluid.

Dimensions

External dimensions, etc.

Tyres (radial)	12R22.5 (FAT6.5)	13R22.5 (FAT7.5)
----------------	---------------------	---------------------

O-Height
(Road-cab roof)

Laden	2650	2690
Unladen	2720	2765

B. Height (road-first step)	550	620
--------------------------------	-----	-----

Internal dimensions

Windscreen-rear cab wall	1310 mm
-----------------------------	---------

Steering wheel-backrest (maximum)	425 mm
--------------------------------------	--------

Floor-steering wheel	640 mm
----------------------	--------

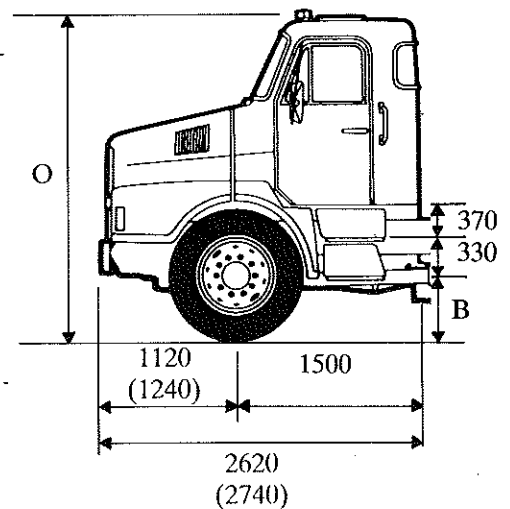
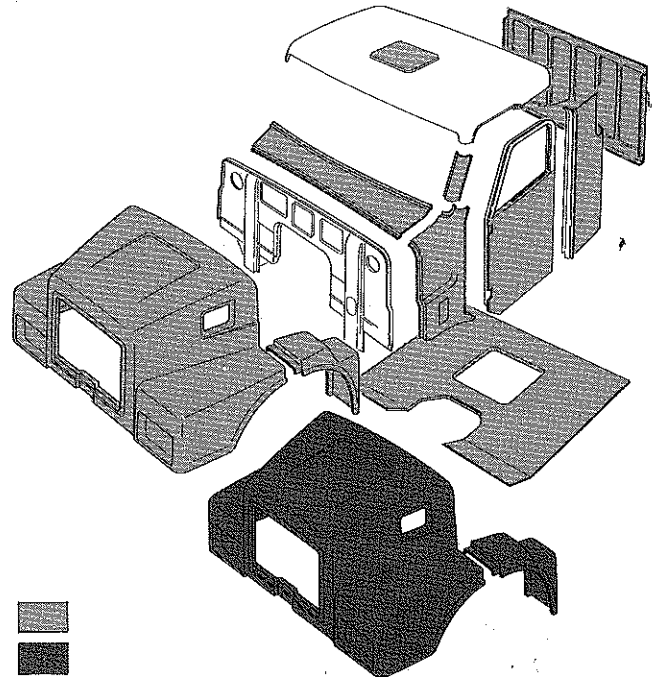

(Intercooler)