

RECOMMENDED RETAIL PRICE LIST - JANUARY 1985

CODE NO.		PRICE	APPROX. WEIGHT
X	STD VEHICLE AS PER SPECIFICATION SHEET	\$66,915.00	6,822 kg

CODE NO.	OPTIONAL EQUIPMENT	PRICE		APPROX. WEIGHT	
		+	-	+	-
X437F	Optional gearbox - Allison MT653 DR automatic	\$8,319.00		10 kg	
X465E	Optional Rear axle - Rockwell S38H	No charge	No charge		162 kg
X466K X466I X466S X466T X466Y	Optional axle ratios - Volvo 5.43:1 - Volvo 6.14:1 - Rockwell 4.87:1 - Rockwell 5.29:1 - Rockwell 5.83:1	No charge No charge No charge No charge No charge	No charge No charge No charge No charge No charge		
X805A X805B X805C X805D X805E	Std. Cab Colour - Crystal White - Volvo Red - Chrome Yellow - Arnhem Ivory - Soft Blue	No charge No charge No charge No charge No charge	No charge No charge No charge No charge No charge		
	Optional Cab Colour - All colours shown on Dulux colour card as optional colours are available in enamel by quoting paint number shown on card	\$ 216.00			
X807A X807B X807C X807D X807E	Chassis Colours - Brown - Black - Red - Grey - Yellow	\$ 190.00 \$ 190.00 \$ 190.00 No charge \$ 190.00	No charge		
X808B X808D X808F X808G X808H X808J X808L X808M X808N X808P X808Q X808R X808T	Paint Application System - Two tone STD colour-enamel (441) - Multi-tone STD colour-enamel (441) - Single tone STD or Opt. colour-Acran (426) - Two tone STD or Opt. colour-Acran (426) - Multi-tone STD or Opt. colour-Acran (426) - Two tone with separate flash-any colour Acran - Single tone metallic (Acran) - Two tone metallic (Acran) - Multi-tone metallic (Acran) - Two tone metallic with separate flash (Acran) - Special colour for chassis - Special colour for chassis, rims, spiders - Special colour for rims and spiders only	\$ 225.00 \$ 542.00 \$ 492.00 \$ 652.00 \$1,004.00 \$1,163.00 \$ 926.00 \$1,007.00 \$1,241.00 \$1,400.00 \$ 190.00 \$ 382.00 \$ 153.00			
X710H X710K X710L X710N	Optional wheelbase - 4000 - 4300 - 4400 - 4800	\$ 896.00 \$ 947.00 \$1,006.00 \$1,037.00		142 kg 185 kg 192 kg 279 kg	

RECOMMENDED RETAIL PRICE LIST - JANUARY 1985

CODE NO.	OPTIONAL EQUIPMENT	PRICE		APPROX. WEIGHT	
		+	-	+	-
X655J	Optional rear suspension - Hendrickson RT380	\$ 247.00			59 kg
X771A	Optional Rims 8.25 x 22.5 - For use with 11R22-5 radial tyres	\$ 469.00		100 kg	
	Tyre Brands - See separate price list for range available				
	Optional Accessories				
X847A	- Air Conditioning Integrated	\$1,035.00		25 kg	
X561A	- Air dryer for brake system	\$ 482.00		20 kg	
X571D	- Air/electrical connection kit for Pig/dog trailers	\$ 432.00		4 kg	
X862F	- Bull bar aluminium	\$1,852.00		75 kg	
X263A	- Fan thermostatic	\$ 400.00		1 kg	
X826A	- Mudguards (rear) plastic + mudflaps - tractor only	\$1,393.00		62 kg	
X862B	- Mudguards (rear) aluminium + mudflaps - tractor only	\$1,522.00		79 kg	
X826C	- Mudguards (rear) 1/4 aluminium + mudflaps	\$ 747.00		11 kg	
X481L	- PTO Side SKU5063	\$ 403.00		11 kg	
X269A	- Radiator special for live hydraulics	\$ 313.00			
X391A	- Radio/cassette AM/FM with speakers	\$ 573.00		11 kg	
X891C	- Stone guard for windscreen	\$ 214.00		4 kg	
X891B	- Sunvisor exterior (steel)	\$ 166.00		9 kg	
X383B	- Tachograph Keinzle 7 day (3 function)	\$ 442.00		1 kg	
X269F	- Insect screen for radiator	\$ 120.00			

These prices are recommended only and may be amended by Volvo Australia Pty. Ltd. at any time.

R.S.P. PRICE 68725.01-85

SALES TAX COMPONENT = 12.9% of recommended retail price

Volvo Australia Pty. Ltd.
(Incorporated in New South Wales)

RATINGS:

FRONT AXLE:	6500 KG (TECHNICALLY PERMITTED)
REAR AXLE:	18000 KG (TECHNICALLY PERMITTED)
GROSS VEHICLE MASS (GVM):	23060 KG WITH 10.00x20 TYRES 24000 KG WITH 11Rx22.5 STEEL RADIAL TYRES
GROSS COMBINATION MASS (GCM):	36500 KG WITH SR62 GEARBOX 32000 KG WITH MT653DR GEARBOX ON APPLICATION APPROVAL

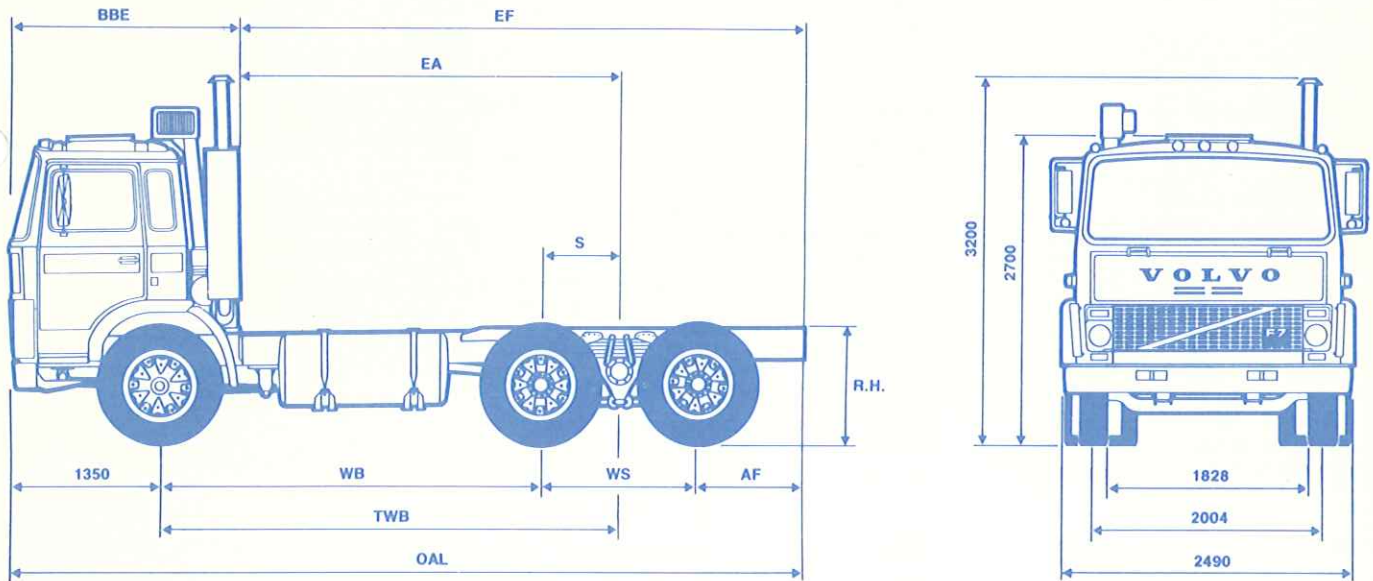

CHASSIS DIMENSIONS MM

		BGT18/RT380	R102W	BGT18/RT380	R102W
WB	Wheelbase	3200	3200	4800	4800
TWB	Theoretical wheelbase	3885	3860	5458	5460
BBE	Bumper back of exhaust Short Cab (Long Cab)	2014 (2614)	2014 (2614)	2014 (2614)	2014 (2614)
EA	Back of exhaust to centre bogie Short Cab (Long Cab)	3221 (2621)	3196 (2596)	4821 (4221)	4796 (4196)
EF	Back of exhaust to end of frame Short Cab (Long Cab)	4844 (4244)	4844 (4244)	8344 (7744)	8344 (7744)
AF	Rear overhang	938	988	2838	2888
OAL	Overall length	6858	6858	10358	10358
RH	Height at centre bogie - Laden	1009/1005	992	1001/1000	987
	- Unladen	1062/1049	1042	1059/1044	1037
Turning Circle	Kerb to kerb	14950	14950	19100	19100

Note RH to top of turntable "L" profiles for WB = 3200

WS - Wheel Spacing R102W 1320 mm
RTA380 1370 mm

CHASSIS WEIGHTS KG

	BGT18/RT380	R102W	BGT18/RT380	R102W
Front axle	3760/3760	3760	3760/3760	3760
Rear Axle	3293/3072	2804	3595/3274	3124
Total chassis weight	7053/6832	6564	7355/7034	6884

Note 1. Chassis weights include SR62 gearbox, CTEV87 rear axle, 10.00x20 tyres, oil and water, but no fuel or spare wheel.
2. *Tare Weights shown are approximate

S = Centre of Axle to load centre of gravity. This calculation is dependent on individual truck tare weight: after optional equipment is fitted and fuel tanks to maximum capacity. This figure should always be calculated in acc. with the salesman's manual.

ADDITIONAL EQUIPMENT WEIGHT - KG

		Front	Rear	Total
Fuel Tanks (Full)	3200	+173	+150	+323
	4800	+217	+106	+323

STANDARD EQUIPMENT

ENGINE T070F INTERCOOLER

Six cylinder four stroke direct injection turbo-charged diesel engine fitted with air charge intercooler. Exhaust pressure regulator (exhaust brake) and starting heater are standard. All speed engine governor.

Capacity:	6.7 litres
Bore:	104.77 mm
Stroke:	130 mm
Compression Ratio:	14.5:1
Oil Capacity:	21 litres
Cooling System Capacity:	31 litres
Exhaust:	Single outlet vertical silencer mounted on left side
Air Cleaner:	Dual element type with cyclone pre-cleaner
Economy Speed Range:	1300 to 2100 rpm.
Net ISO/SAE output:	173 kw (235 hp metric) @ 2400 rpm

Net ISO/SAE torque: 825 Nm @ 1400 rpm
Net output and torque according to ISO 1585, SAE J1349. Smoke requirements according to ECE Reg 24, U.S. Federal Register, Swedish Norms and Australian Design Rule 30.

CLUTCH-KF214F

Twin dry plate with torsion dampening springs. Hydraulic clutch control with air servo operation.

Total Area:	2650 sq cm
Clutch Plate Diameter:	356 mm
Pressure Plate Diameter:	356 mm

GEARBOX - SR62

Fully synchromesh 8 speed range gearbox with splitter to give 16 forward speeds. Air operated splitter and range control mounted on gearshift knob.

Oil Capacity:	14.7 litres
Ratios:	1st 11.22/9.46
	2nd 7.84/6.611
	3rd 5.50/4.64
	4th 3.93/3.31
	5th 2.86/2.41
	6th 2.00/1.68
	7th 1.40/1.18
	8th 1.029/8.67

Provision for side and rear mounted power take-offs.

PROPELLER SHAFT - 1800 SERIES

AXLE-REAR BOGIE - CTEV87

Volvo Single Reduction Tandem with power divider lock and differential locks in each axle.

Capacity:	26,000 Kg.
Ratios:	4.87:1
Oil Capacity:	First Drive Axle, 20 litres Second Drive Axle, 9 litres

CAB - SHORT

Model: KH

Construction: All steel safety cab with hydraulic tilt to 52°. Cab mounted on rubber bushes at front and on coil springs and shock absorbers at rear. Full sound and thermal insulation.

Equipment: Full sprung driver's and fixed passenger's seat; electrically operated two speed wipers and three arms and intermittent switch, halogen head lamps, 5 roof marker lights, single air horns, roof hatch. Fire extinguisher. Seat belts fitted standard for driver and passenger.

Heating & Cooling: Thermostatically controlled heater and demister.

Instrumentation: Electronic speedometer, tachometer, water temperature gauges, voltmeter, engine oil and air pressure gauges, fuel level gauge. Warning lamps for high water temp; low water level; low oil pressure; low air pressure; battery charging; starter element; cab lock; power divider and diff locks; blocked air cleaner; high beam; park brake; gearbox overdrive and direction indicator.

Finish: Choice of colours, Crystal white, Volvo red, Chrome yellow, Arnhem ivory, Soft blue.

Chassis colour: Grey

FRAME - RAM 3

Steel rolled channel section with cold rivetted crossmembers.

Frame Width:	800 mm
Web Height:	273 mm
Web Thickness:	7 mm
Flange Width:	85 mm
Flange Thickness:	13 mm

Aluminium bumper bar.

WHEELBASE - STANDARD 3200 mm

See option list, for other sizes.

FUEL TANK

Single aluminium tank, of 390 litres capacity mounted on left side.

BRAKES - SYSTEM TYPE: K-BROMS

Service: Compressed air "S" cam with separate circuits for front and rear. Hand control for trailer brakes.

Parking: Air operated spring brakes operating on front axle and first drive axle.

Exhaust Brake: Electro-pneumatic operated by foot switch.

Brake Size:	Front, 413x152 mm
	Rear, 394x203 mm
Brake Area:	Front, 2415 cm ²
	Rear, 6100 cm ²
	Total, 8515 cm ²

Compressor:	Tufo 700
Capacity:	375 l/min at 2000 rpm
Pressure:	700 kPa
Working Pressure:	650 kPa - 790 kPa
Reservoir Capacity:	1x50 litre, 2x25 litre, 1x30 litre. Total 130 litres.

SUSPENSION - FRONT

Parabolic leaf springs with double acting hydraulic shock absorbers and hollow rubber springs. Anti-roll stabilizer bar.

Spring Type:	FFJ-P2
Length:	1780 mm
Width:	100 mm
No. of leaves:	3
Capacity:	6500 kg

SUSPENSION - REAR BOGIE

Volvo single point inverted with multi-leaf springs on centre pivot trunion, for use with Volvo axles only.

Bogie Suspension

Type:	BGT18
Spring Type:	BFJ-K1
Length:	1400 mm
Width:	100 mm
No. of leaves:	5
Capacity:	18000 kg

ELECTRICAL

24 volt system. Four 61 amp/hour 12 volt batteries and isolation switch. Manual reset circuit breakers fitted standard.

Alternator:	1300 w (45 amp @ 28 volts)
Battery Capacity:	122 A/hr (at 24 volts)
Starter Motor:	4 kw (5.3 hp)

STEERING

Fully integral power steering recirculating ball and nut.

Steering Wheel Dia:	500 mm
Ratio:	18.6:1
Turns lock to lock:	4.2 (approx)

Front wheel steering lock angle, inner wheel: 50°

AXLE - FRONT - FAT 6.5

Drop forged I Beam with oil filled hub.

Capacity: 6500 kg

WHEELS AND TYRES

Six spoke spider hubs with demountable rims and conventional tyres. 11 off tyres and rims supplied.

Rim Size:	7.50x20
Tyre Size:	10.00x20-14 ply front 10.00x20-12 ply rear 10.00x20-14 ply spare

OPTIONAL EQUIPMENT

OPTIONAL GEARBOX - MT653DR

Automatic Transmission with torque converter Automatic lock up on two highest speeds.

Oil Capacity:	16.5 litres
Ratios:	1st 8.04
	2nd 3.58
	3rd 2.09
	4th 1.39
	5th 1.00
	Reverse 5.67

Torque Amplification at Stall = 1.86

Note: MT653 transmission not available on W.B. 3200 mm.

OPTIONAL AXLES-REAR BOGIE - S38H

Rockwell Single Reduction Tandem drive with power divider.

Capacity:	17240 kg
Ratios:	4.87:1
Oil Capacity:	First Drive Axle, 19 litres Second Drive Axle, 17 litres.

OPTIONAL REAR AXLE RATIOS

	DIFF. RATIO.
MT653DR/Volvo axle	6.14:1, 5.43:1
MT653DR/Rockwell axle	5.83:1, 5.29:1
SR62/Volvo axle	5.43:1
SR62/Rockwell axle	4.87:1, 5.29:1

OPTIONAL CAB - LONG SLEEPER

Model: LH

See specification as for short cab, but with sleeper bunk fitted.

OPTIONAL WHEELBASES

The following WB variants are available as an option:

	3600
	4000
	4300 *most common choice
	4400
	4800

OPTIONAL FUEL TANK

The choice of sizes is as follows:

270 litre mounted on R.H. side.
270 litre mounted on L.H. side

OPTIONAL SUSPENSION - REAR BOGIE

Reyco 4 spring with centre rocker, four torque rods (two each axle), for use with Rockwell axles only.

Model:	R102W
Spring length:	1000 mm
Width:	76mm
Leaves/thickness:	13x10 mm
Capacity:	18,160 kg

OPTIONAL SUSPENSION - REAR BOGIE

Hendrickson suspension with steel walking beam and semi-elliptical leaf springs for use with Rockwell axles only.

Model:	RT380
Capacity:	17,240 kg
No of leaves:	4x13 mm 7x11 mm

OPTIONAL WHEELS AND TYRES

Six spoke spider hubs with demountable rims and steel radial tyres. 11 off tyres and rims supplied.

Rim Size:	8.25x22.5
Tyre Size:	11R 22.5 tubeless 16 ply

OPTIONAL ACCESSORIES

Stereo FM/AM radio/cassette player with speakers
Air dryer for brake system
Thermostatic fan
Integrated air conditioning
Choice of rear mounted PTO
Choice of side mounted PTO
Choice of combination PTO/Pumps
Choice of turntables for tractors
Choice of rear mudguards with mud flaps fitted
Keinle 7 day Tachograph
Exterior sunvisor (steel)
Windscreen stone guard
Tractor air/electrical connection kit for trailer
Aluminium bull bar
Special radiator and intercooler for live hydraulics

RECOMMENDED RETAIL PRICE LIST - JANUARY 1985

CODE NO.		PRICE	APPROX. WEIGHT
T	STD VEHICLE AS PER SPECIFICATION SHEET	\$81,908.00	7053 kg

CODE NO.	OPTIONAL EQUIPMENT	PRICE		APPROX. WEIGHT	
		+	-	+	-
T437F	Optional gearbox - Allison MT653 DR	\$6,750.00			155 kg
T491M	Optional gearbox cooler - MT653 DR Heavy Duty Industrial Kit	\$ 500.00		30 kg	
T465D	Optional axle - Rockwell S38H	\$ 200.00			162 kg
T466K T466I T466T T466S T466Y	Optional axle ratios - Volvo 5.43:1 - Volvo 6.14:1 - Rockwell 5.29:1 - Rockwell 4.87:1 - Rockwell 5.83:1	No charge No charge No charge No charge No charge	No charge No charge No charge No charge No charge		
T800B	Optional cab - Long sleeper (LH)	\$1,340.00		155 kg	
T805A T805B T805C T805D T805E	Std. cab colour - Crystal White - Volvo Red - Chrome Yellow - Arnhem Ivory - Soft Blue	No charge No charge No charge No charge No charge	No charge No charge No charge No charge No charge		
	Optional Cab Colour - All colours shown on Dulux colour card as optional colours are available in enamel by quoting paint number shown on card	\$ 216.00			
T807A T807B T807C T807D T807E	Chassis colour - Brown - Black - Red - Grey - Yellow	\$ 190.00 \$ 190.00 \$ 190.00 No charge \$ 190.00	No charge		
T808B T808D T808F T808G T808H T808J T808L T808M T808N T808P T808Q T808R T808T	Paint Application System - Two tone STD colour-enamel (441) - Multi-tone STD colour-enamel (441) - Single tone STD or Opt. colour-Acran (426) - Two tone STD or Opt. colour-Acran (426) - Multi-tone STD or Opt. colour-Acran (426) - Two tone with separate flash - any colour Acran - Single tone metallic (Acran) - Two tone metallic (Acran) - Multi-tone metallic (Acran) - Two tone metallic with separate flash (Acran) - Special colour for chassis - Special colour for chassis, rims, spiders - Special colour for rims and spiders only	\$ 225.00 \$ 542.00 \$ 492.00 \$ 652.00 \$1,004.00 \$1,163.00 \$ 926.00 \$1,007.00 \$1,241.00 \$1,400.00 \$ 190.00 \$ 382.00 \$ 153.00			

RECOMMENDED RETAIL PRICE LIST - JANUARY 1985

CODE NO.	OPTIONAL EQUIPMENT	PRICE		APPROX. WEIGHT	
		+	-	+	-
T710F T710H T710K T710L T710N	Optional wheelbase - 3600 - 4000 - 4300 - 4400 - 4800	\$ 378.00 \$ 896.00 \$ 947.00 \$1,006.00 \$1,037.00		82kg 176kg 206kg 213kg 302kg	
T234B T234A T234C	Optional fuel tanks - 270 litre RH side in addition to STD tank - 270 litre LH side - 2 x 270 litre mounted on RH side + LH side to give total of 540 litres	\$1,280.00 \$ 63.00 \$1,280.00		56kg 50kg	6kg
T655L T655J	Optional rear suspension - Reyco R102W - Hendrickson RT380	No charge \$ 247.00	No charge		309kg 59kg
T771A	Optional Rims - 8.25 x 22.5 - For use with 11R22.5 radial tyres	\$ 467.00		100kg	
	Tyre Brands See separate price list for range available				
T874A T561A T571A T571B T571C T862F T263A T826A T826B T826C T481C T481D T481N T481Q T481G T481H T269B T391A T891B T891C T383B T992A T992B T992C T269F	Optional Accessories - Air conditioning integrated - Air dryer for brake system - Air electrical kit - Pogo + push on connectors - Air electrical kit - Pogo + gladhand connectors - Air electrical kit - mounted behind turntable - Bull bar aluminium - Fan thermostatic - Mudguards (rear) plastic + mudflaps - tractor only - Mudguards (rear) aluminium + mudflaps - tractor only - Mudguards (rear) 1/4 aluminium + mudflaps - PTO Rear BKU6059 - PTO Rear BKU6123 - PTO Side SKU6077 - PTO Side SKMT124 (for MT653) - PTO Rear/pump BKUH6039 - PTO Rear/pump BKUH6058 - Radiator (special) and intercooler for live hydraulics - Radio Cassette AM/FM with speakers - Sunvisor exterior (steel) - Stoneguard for windscreen - Tachograph Keinzle 7 day (3 function) - Turntable Holland HAP 40 - Turntable Franklin Ball Race - Turntable Carrimore Top "C" - Insect screen for Radiator/Intercooler	\$1,035.00 \$ 482.00 \$ 398.00 \$ 396.00 \$ 176.00 \$1,852.00 \$ 323.00 \$1,393.00 \$1,522.00 \$ 747.00 \$ 286.00 \$ 753.00 \$ 403.00 \$ 876.00 \$1,310.00 \$1,371.00 \$ 607.00 \$ 573.00 \$ 167.00 \$ 214.00 \$ 442.00 \$1,798.00 \$3,695.00 \$1,522.00 \$ 120.00		25kg 20kg 7kg 7kg 3kg 75kg 3kg 62kg 79kg 11kg 9kg 20kg 11kg 17kg 30kg 30kg 11kg 9kg 4kg 1kg 240kg 358kg 115kg	

These prices are recommended only and may be amended by Volvo Australia Pty. Ltd. at any time.

R.S.P. PRICE 68727.01-85

SALES TAX COMPONENT = 12.9% of recommended retail price

Volvo Australia Pty. Ltd.
(Incorporated in New South Wales)