

## RECOMMENDED RETAIL PRICE LIST - JANUARY 1985

CODE NO.		PRICE	APPROX. WEIGHT
S	STD VEHICLE AS PER SPECIFICATION SHEET	\$94,350.00	8239 kg

CODE NO.	OPTIONAL EQUIPMENT	PRICE		APPROX. WEIGHT	
		+	-	+	-
S437F	<b>Optional gearbox</b> - Allison MT653 DR	\$6,750.00			155 kg
S491M	<b>Optional Gearbox Cooler</b> - MT653 DR Heavy Duty Industrial Kit	\$ 800.00		30 kg	
S465D	<b>Optional axles</b> - Rockwell S38H	\$ 200.00			162 kg
S466I S466K S466T S466Z S466S S466Y	<b>Optional axle ratios</b> - Volvo 6.14:1 - Volvo 5.43:1 - Rockwell 5.29:1 - Rockwell 5.43:1 - Rockwell 4.87:1 - Rockwell 5.83:1	No charge No charge No charge No charge No charge No charge	No charge No charge No charge No charge No charge No charge		
S800B	<b>Optional cab</b> - Long sleeper (LH)	\$1,340.00		155 kg	
S805A S805B S805C S805D S805E	<b>Std. cab colour</b> - Crystal White - Volvo Red - Chrome Yellow - Arnhem Ivory - Soft Blue	No charge No charge No charge No charge No charge	No charge No charge No charge No charge No charge		
	<b>Optional Cab Colour</b> - All colours shown on Dulux colour card as optional colours are available in enamel by quoting paint number shown on card	\$ 216.00			
S807A S807B S807C S807D S807E	<b>Chassis Colours</b> - Brown - Black - Red - Grey - Yellow	\$ 190.00 \$ 190.00 \$ 190.00 No charge \$ 190.00	No charge		
S808B S808D S808F S808G S808H S808J S808L S808M S808N S808P S808Q S808R S808T	<b>Paint Application System</b> - Two tone STD colour-enamel (441) - Multi-tone STD colour-enamel (441) - Single tone STD colour-Acran (426) - Two tone STD or Opt. colour-Acran (426) - Multi-tone STD or Opt. colour-Acran (426) - Two tone with separate flash - any colour Acran - Single tone metallic (Acran) - Two tone metallic (Acran) - Multi-tone metallic (Acran) - Two tone metallic with separate flash (Acran) - Special colour for chassis - Special colour for chassis, rims, spiders - Special colour for rims and spiders only	\$ 225.00 \$ 542.00 \$ 492.00 \$ 652.00 \$1,004.00 \$1,163.00 \$ 926.00 \$1,007.00 \$1,241.00 \$1,400.00 \$ 190.00 \$ 382.00 \$ 153.00			

### RECOMMENDED RETAIL PRICE LIST - JANUARY 1985

CODE NO.	OPTIONAL EQUIPMENT	PRICE		APPROX. WEIGHT	
		+	-	+	-
S710K S710N S710S	<b>Optional wheel base</b> - 4300 mm - 4800 mm - 5600 mm	\$ 83.00	\$ 758.00 \$ 672.00	56 kg	103 kg 37 kg
S234D	<b>Optional fuel tank</b> - 390 litres LH side	No charge	No charge	6 kg	
S655A S655J S655L	<b>Optional rear suspension</b> - Volvo BGT 20 - Hendrickson RT380 - Reyco R102W	No charge \$ 247.00 No charge	No charge No charge	84 kg	59 kg 309 kg
S771A	<b>Optional Rims</b> - 8.25 x 22.5 - For use with 11R22.5 radial tyres	\$ 555.00		120 kg	
	<b>Tyre Brands</b> - See separate price list for range available				
S874A S561A S571D S862F S263A S481C S481D S481Q S269B S391A S891B S891C S383B S269F	<b>Optional accessories</b> - Air conditioning (integrated) - Air dryer for brake system - Air electrical connection for Pig/dog trailer - Bull bar (aluminium) - Fan (thermostatic) - PTO Rear BKU6059 - PTO Rear BKU6123 - PTO Side SKMT124 (for MT653) - Radiator & intercooler for live hydraulics - Radio/cassette AM/FM with speakers - Sunvisor (exterior) - Stoneguard for windscreen - Tachograph Keinzle 7 day (3 function) - Insect screen for Radiator/Intercooler	\$1,035.00 \$ 482.00 \$ 416.00 \$1,852.00 \$ 323.00 \$ 286.00 \$ 753.00 \$ 876.00 \$ 607.00 \$ 573.00 \$ 167.00 \$ 214.00 \$ 442.00 \$ 120.00		25 kg 20 kg 4 kg 75 kg 3 kg 9 kg 20 kg 17 kg  11 kg 9 kg 4 kg 1 kg	

These prices are recommended only and may be amended by Volvo Australia Pty. Ltd. at any time.

R.S.P. PRICE 68728.01-85

SALES TAX COMPONENT = 12.9% of recommended retail price

Volvo Australia Pty. Ltd.  
(Incorporated in New South Wales)

**RATINGS:**

FRONT AXLE:	10000 KG (TECHNICALLY PERMITTED)
REAR AXLE:	18000 KG (TECHNICALLY PERMITTED)
GROSS VEHICLE MASS (GVM):	27000 KG WITH 10.00x20 TYRES 27000 KG WITH 11Rx22.5 STEEL RADIAL TYRES
GROSS COMBINATION MASS (GCM):	36500 KG WITH SR62 GEARBOX 32000 KG WITH MT653 GEARBOX ON APPLICATION APPROVAL

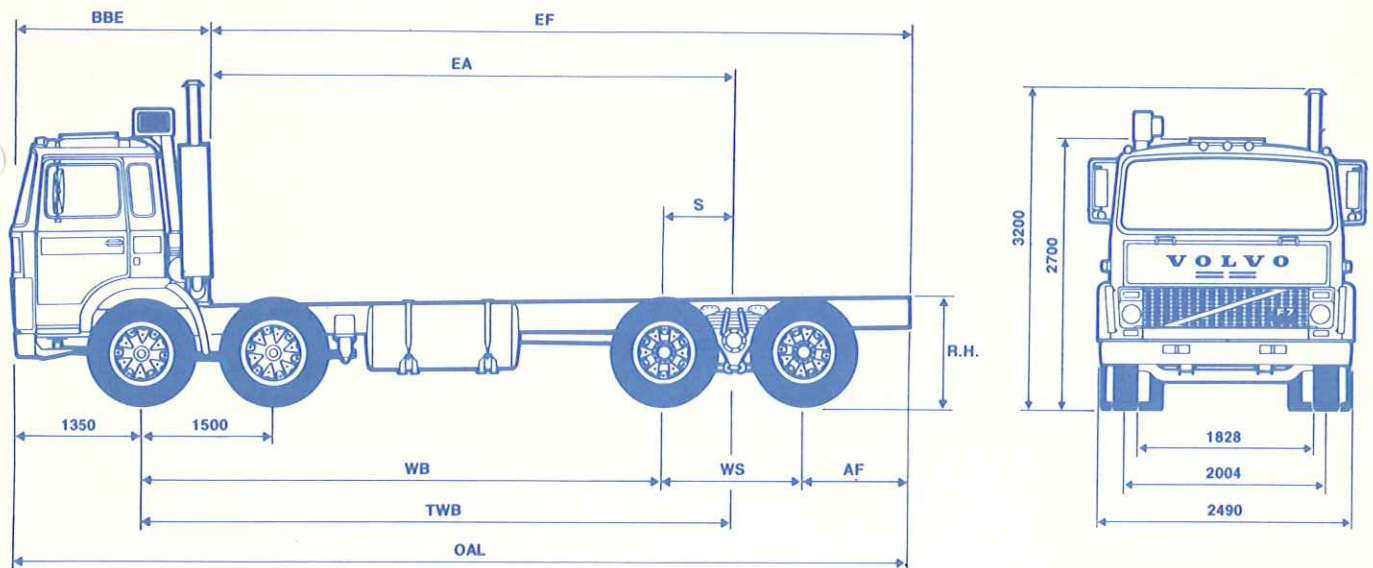
**CHASSIS DIMENSIONS MM**

		BGT18/RT380	R102W	BGT18/RT380	R102W
WB	Wheelbase	5200	5200	5600	5600
TWB	Theoretical wheelbase	5885	5860	6285	6260
BBE	Bumper back of exhaust Short Cab (Long Cab)	2014 (2614)	2014 (2614)	2014 (2614)	2014 (2614)
EA	Back of exhaust to centre bogie Short Cab (Long Cab)	5221 (4621)	5196 (4596)	5621 (5021)	5596 (4996)
EF	Back of exhaust to end of frame Short Cab (Long Cab)	7044 (6444)	7044 (6444)	7904 (7304)	7904 (7304)
AF	Rear overhang	1138	1188	1598	1648
OAL	Overall length	9058	9058	9918	9918
RH	Height at centre bogie – Laden – Unladen	1001/1005 1056/1049	987 1037	1001/1000 1056/1044	987 1037
Turning Circle	Kerb to kerb	20150	20150	21150	21150

WS – Wheel Spacing R102W 1320  
RTA380 1370

**CHASSIS WEIGHTS KG**

	BGT18/RT380	R102W	BGT18/RT380	R102W
Front axle	5026/5026	5026	5049/5049	5049
Rear Axle	3213/2992	2738	3251/3030	2780
Total chassis weight	8329/8018	7764	8300/8079	7829

Note 1. Chassis weight includes SR62 gearbox, CETV87 rear axle, 10.00x20 tyres, oil and water, but no fuel or spare wheel.  
2. \* Tare Weights shown are approximate

S = Centre of Axle to load centre of gravity. This calculation is dependent on individual truck tare weight: after optional equipment is fitted and fuel tanks to maximum capacity. This figure should always be calculated in acc. with the salesman's manual.

**ADDITIONAL EQUIPMENT WEIGHT – KG**

		Front	Rear	Total
Fuel Tanks (Full)	5200	+136	+90	+226
	5600	+143	+83	+226

## STANDARD EQUIPMENT

### ENGINE TD70F INTERCOOLER

Six cylinder four stroke direct injection turbo-charged diesel engine fitted with air charge intercooler. Exhaust pressure regulator (exhaust brake) and starting heater are standard. All speed engine governor.

**Capacity:** 6.7 litres  
**Bore:** 104.77 mm  
**Stroke:** 130 mm  
**Compression Ratio:** 14.5:1  
**Oil Capacity:** 21 litres  
**Cooling System Capacity:** 31 litres  
**Exhaust:** Single outlet vertical silencer mounted on left side

**Air Cleaner:** Dual element type with cyclone pre-cleaner

**Economy Speed Range:** 1300 to 2100 rpm.

**Net ISO/SAE output:** 173 kw (235 hp metric) @ 2400 rpm

**Net ISO/SAE torque:** 825 Nm @ 1400 rpm

Net output and torque according to ISO 1585, SAE J1349. Smoke requirements according to ECE Reg 24, U.S. Federal Register, Swedish Norms and Australian Design Rule 30.

### CLUTCH-KF214F FOR SR62 GEARBOX

Twin dry plate. Hydraulic clutch control with air servo operation.

**Total Area:** 2650 sq cm  
**Clutch Plate Diameter:** 356 mm  
**Pressure Plate Diameter:** 356 mm

### GEARBOX - SR62

8 speed fully synchromesh range change gearbox with splitter to give 16 forward speeds. Air operated splitter and range control mounted on gearshift knob.

**Oil Capacity:** 14.7 litres  
**Ratios:**

1st	11.22/9.46
2nd	7.84/6.61
3rd	5.50/4.64
4th	3.93/3.31
5th	2.86/2.41
6th	2.00/1.68
7th	1.40/1.18
8th	1.00/0.84
Reverse	10.29/8.67

### PROPELLOR SHAFT - 1800 SERIES

### AXLE-REAR BOGIE - CTEV87

Volvo Single Reduction Tandem with power divider lock and differential locks in each axle.

**Capacity:** 26000 kg  
**Ratios:** 4.87:1  
**Oil Capacity:** First Drive Axle 20 litres  
 Second Drive Axle 9 litres

### CAB - SHORT

**Model:** KH

**Construction:** All steel safety cab with hydraulic tilt to 52°. Cab mounted on rubber bushes at front and on coil springs and shock absorbers at rear. Full sound and thermal insulation.

**Equipment:** Full sprung driver's and fixed passenger's seat; electrically operated two speed wipers and three arms and intermittent switch, halogen head lamps, 5 roof marker lights, single air horns, roof hatch. Fire extinguisher. Lap seat belts fitted standard for driver and passenger.

**Heating & Cooling:** Thermostatically controlled heater and demister.

**Instrumentation:** Electronic Speedometer, tachometer, fuel and water temperature gauges, voltmeter, engine oil and air pressure gauges. Warning lamps for high water temp; low water level; low oil pressure; low air pressure; power divider; blocked air cleaner, high beam; park brake; gearbox overdrive and direction indicator.

**Finish:** Choice of colours, Crystal white, Volvo red, Chrome yellow, Arnhem ivory, Soft blue.

**Chassis colour:** Grey

### FRAME - RAM 3

Steel rolled channel section with cold rivetted crossmembers.

**Frame Width:** 800 mm  
**Web Height:** 273 mm  
**Web Thickness:** 7 mm  
**Flange Width:** 85 mm  
**Flange Thickness:** 13 mm

Aluminium bumper bar.

### WHEELBASE - STANDARD 5200 mm

See option list, for other sizes.

### FUEL TANK

Single aluminium tank, of 270 litres capacity mounted on left side.

### BRAKES - SYSTEM TYPE: K-BROMS

**Service:** Compressed air "S" cam with separate circuits for front and rear. Hand control for trailer brake.

**Parking:** Air operated spring brakes operating on second steer axle and first driving axle.

**Exhaust Brake:** Electro-pneumatic operated by foot switch.

**Brake Size:** Front, 413x152 mm  
 Rear, 394x203 mm

**Brake Area:** Front, 4830 cm<sup>2</sup>  
 Rear, 6100 cm<sup>2</sup>

Total, 10930 cm<sup>2</sup>

**Compressor:** Tuflo 700.

**Capacity:** 375 lit/min at 2000 rpm

**Pressure:** 700 kPa.

**Working Pressure:** 650 kPa -790 kPa.

**Reservoir Capacity:** 1x50 litre, 1x25 litre, 2x40 litre.

Total 155 litres.

### SUSPENSION - FRONT

Twin front axle non load share design with conventional semi-elliptical leaf springs and double acting hydraulic shock absorbers, hollow rubber springs fitted.

**Spring Type:** FFJ-K1  
**Length:** 1st axle 1597 mm  
 2nd axle 1300 mm

**Width:** 100 mm  
**No. of leaves:** 1st axle 8  
 2nd axle 8

**Capacity:** 10000 kg

### SUSPENSION - REAR BOGIE

Volvo single point inverted with multi-leaf springs on centre pivot trunion for use with Volvo axles only.

#### Bogie Suspension

**Type:** BGT18

**Spring Type:** BFJ-K1

**Length:** 1400 mm

**Width:** 100 mm

**No. of leaves:** 5

**Capacity:** 18000 kg

### ELECTRICAL

24 volt system. Four 61 Ahr 12 volt batteries and isolation switch. Manual reset circuit breakers fitted standard.

**Alternator:** 1300 w(45 amp @ 28 volts)

**Battery Capacity:** 122 Ahr (at 24 volts)

**Starter Motor:** 4 kw (5.3 hp)

### STEERING

Fully integral power steering recirculating ball and nut.

**Steering Wheel Dia:** 500 mm

**Ratio:** 25.5:1

**Turns lock to lock:** 5.7:1

Front wheel steering lock angle, inner wheel: 50° first axle, 42.5° second axle.

### AXLE - FRONT - FAT 12

Drop forged I Beams installed in tandem arrangement, with oil filled hubs.

**Capacity:** 10,000 kg

### WHEELS AND TYRES

Six spoke spider hubs with demountable rims and conventional nylon tyres. 13 off tyres and rims supplied.

**Rim Size:** 7.50x20

**Tyre Size:** 10.00x20-14 ply front

10.00x20-12 ply rear

10.00x20-14 ply spare

## OPTIONAL EQUIPMENT

### OPTIONAL GEARBOX - MT653DR

Automatic Transmission with torque converter. Automatic lock up on two highest speeds.

**Oil Capacity:** 16.5 litres  
**Ratios:**

1st	8.04
2nd	3.58
3rd	2.09
4th	1.39
5th	1.00
Reverse:	5.67

Torque Amplification at Stall = 1.86

### OPTIONAL AXLE - REAR BOGIE

Rockwell S38H single reduction tandem drive with power divider.

**Model:** S38H  
**Capacity:** 17240 kg  
**Ratio:** 4.87:1  
**Oil Capacity:** First Drive axle 19 litres  
 Second Drive axle 17 litres

### OPTIONAL REAR AXLE RATIOS

MT653DR/Volvo axles 5.43:1, 6.14:1

MT653DR/Rockwell axles 5.29:1, 5.83:1

SR62/Volvo CTEV87 5.43:1, 6.14:1

SR62/Rockwell Axles 4.87:1, 5.29:1

### OPTIONAL CAB - LONG SLEEPER

**Model:** LH

See specification as for short cab, but with sleeper bunk fitted.

### OPTIONAL WHEELBASES

The following W.B. variants are available as an option:

4300

4800

5600

### OPTIONAL FUEL TANKS

The choice of sizes is as follows:

390 litres mounted on L.H.S.

### OPTIONAL SUSPENSION - REAR BOGIE

Volvo single point inverted multi-leaf springs on centre pivot trunion, for use with Volvo axles only.

**Bogie Suspension Model:** BGT20

**Spring Type:** BFJ-K1

**Length:** 1400 mm

**Width:** 100mm

**No. of Leaves:** 8

**Capacity:** 20,000 kg

### OPTIONAL SUSPENSION - REAR BOGIE

Hendrickson suspension with steel walking beam and semi-elliptical leaf springs.

**Model:** RT380

**Capacity:** 17,240 kg

**No of leaves:** 4x13 mm, 7x11 mm

### OPTIONAL SUSPENSION - REAR BOGIE

Reyco 4 spring with centre rocker, four torque rods, (two each axle).

**Model:** R102W

**Spring length:** 1000 mm

**Width:** 76 mm

**Leaves/thickness:** 13x10 mm

**Capacity:** 18,160 kg

### OPTIONAL WHEELS AND TYRES

Six spoke spider hubs with demountable rims and steel radial tyres. 13 off tyres and rims supplied.

**Rim Size:** 8.25x22.5

**Tyre Size:** 11R 22.5 tubeless 16 ply

### OPTIONAL ACCESSORIES

Stereo FM/AM radio/cassette player with speakers

Special radiator and intercooler for live hydraulics

Air dryer for brake system

Thermostatic fan

Integrated air conditioning

Choice of rear mounted P.T.O.

Choice of side mounted P.T.O.

Choice of combination P.T.O./Pumps

Keinzle 7 day tachograph

Exterior sunvisor (steel)

Windscreen stone guard

Choice of mudguards with mud flaps fitted.

Aluminium bull bar