

(2:431)

## DESCRIPTION

F 10 and F 12 trucks are used for all types of heavy transport; long-distance, forestry and construction. By far the most dominating range of use for these vehicles consists of heavy long-distance transport. For this reason the cab has been specially adapted to long-distance transport and high priority given to driver environment. The cab can also be specified more specifically for forestry or construction site work. For these two applications, the bumper is moved up 90 mm (and moved forward 130 mm) to give higher ground clearance. A mock-leather engine casing cover is available as an optional extra.

A considerable proportion of long-distance transport today is carried out with a gross laden weight which is considerably less than the maximum permissible train weight, this depending on the fact that goods are bulky. As a result, the cab must not be unnecessarily large. F 10 and F 12 trucks can be provided with either a long or a short cab.

**Exterior:** The cab naturally gives the vehicle its character. It has large glazed areas facing forwards and in the doors but unnecessarily large glazed areas on the sides have been avoided in order to provide the most effective insulation possible. The engine air intake is located at the rear edge of the cab above the cab roof.

The light-alloy bumper is extended far downwards in order to meet other vehicles bumper to bumper.

Spoilers in the front edge of the cab regulate the slipstream so as to minimize the amount of dirt splashed up onto the doors, door windows and rear view mirrors.

The windscreen is kept clean by three windscreen wipers. Grab handles on the front make it easy to clean off the windscreen. A roof hatch is standard.



**Cab mountings:** One of the main objectives in the design of F 10/F 12 trucks has been to create first-class driver comfort. For this reason the cab has been completely insulated from the frame. It rests on four coil springs – two front and two rear. Movements are damped by means of a telescopic shock absorber at each spring. There is also a stabilizer at the front.

The cab mounting system absorbs all high-frequency vibrations from the chassis.

### Feature

- All-steel cab, impact tested
- Cab tilting angle 60°, revealing entire front end
- Unique surface treatment process, four coats
  
- Well insulated, dense bitumen material
- Big windows, minimum of blind angles, three windscreen wipers
- High capacity heating and ventilation system, integrated air conditioning
- Carefully balanced suspension system
- Sprung driving seat
- Spacious and well appointed interior
- Excellent entry/exit
- Door opening angle 90°
- Sleeper cab with bunk optional
- Higher bumper optional

### Benefit

- Driver safety
- Service kindly
- High quality level, excellent resistance to corrosion, durable finish
- Low noise level
- Excellent visibility
  
- Fast and efficient, draught-free ideal in-cab temperature.
- First class driver comfort
  
- Giving higher ground clearance for forestry and construction site work.

# F 10 and F 12 Cab

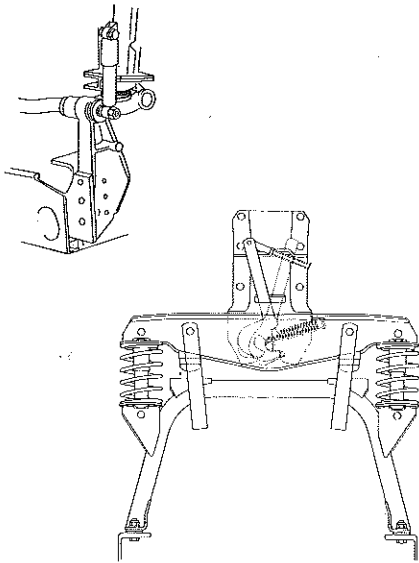

## Level-controlled rear cab mountings:

An optional extra for the sleeper cab. This levelling device compensates the tendency of the cab to lean rearwards due to the weight of extra equipment, acceleration forces and air resistance.

**NOTE!** This levelling system is recommended when a roof-mounted air deflector has been specified.

The levelling system consists of air springs which supplement the cab shock absorbers. Pressure from the regular air system of the vehicle is used to inflate the springs. This is controlled by a valve which senses the leaning tendency of the cab.

**Cab tilting:** Hydraulic cab tilting is standard. Maximum tilting requires 64 mm pump strokes at a force of 25 kp for a short cab and 26 kp for a long cab. The locking unit and pump are both operated from the right-hand side of the cab. The cab has a tilting angle of 60°.

**Entry:** The outside door handle is located low down and convenient in the lower corner of the door. The door opening angle is 90°. Entry and exit are facilitated by means of two liberally dimensioned handrails, one on each side of the door. The footsteps are robust, wide and anti-slip. Entry height is influenced by tyre size. The dimensions drawing on the last page shows the different entry measurements. When the door is opened, a lamp above the door lights up the steps.

## Interior:

Driver environment influences the technique of the driver and also the economic yield provided by the truck. This makes it important for the cab to be roomy, comfortable, airy and pleasant.

**Driving position:** Both seats are made by Isringhausen and are spring-loaded. The seat can be adjusted exactly as desired through a wide range of settings. The seat backrest can be folded 64° rearwards. It can also be folded forwards against the cushion. The fore-and-aft control range is 130 mm. The entire height and inclination of the seat can be set to seven positions. The control range is 65 mm. The stiffness of the springing can be adjusted to suit driver weight. Control range 60–135 kg. The steering wheel can be adjusted to different positions and can also be moved fore-and-aft (adjustment range 20°) and upwards-downwards (adjustment range 40 mm). Electrically heated driving seat available as optional extra.

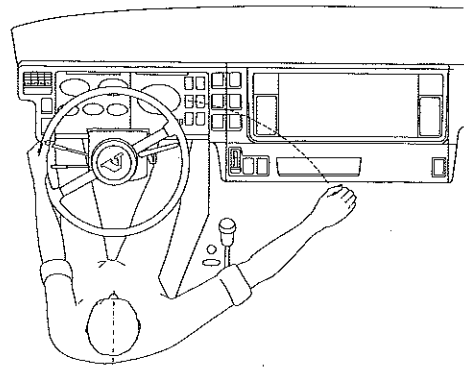

**The instruments and controls** are located partly right in front of the driver, partly on a central console. The driver has the gear lever, hand throttle and stop control right beside him. Within convenient reach on the console is the parking brake lever.

Here is an explanation of the symbols used:

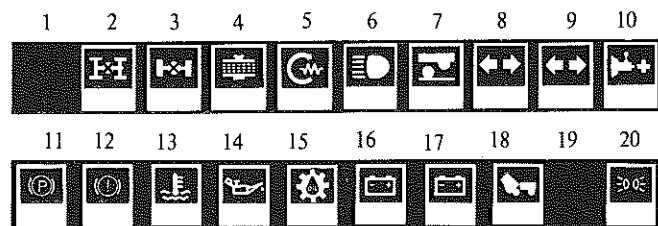

1. Not connected
2. Control lamp, differential lock between axles
3. Control lamp, differential lock between wheels
4. Control lamp, blocked air cleaner
5. Control lamp, pre-heating (electric starter element)
6. Control lamp, full headlights
7. Control lamp, bogie lift or Robson drive (only 6x2 trucks)
8. Control lamp, turn indicators, tractor unit
9. Control lamp, turn indicators, trailer
10. Control lamp, overdrive engaged (SR 62) or excessively high oil temperature (MR 62 B)
11. Warning lamp, parking brake
12. Warning lamp, brake system (service brakes)
13. Warning lamp, excessively high coolant temperature or excessively low coolant level
14. Warning lamp, oil pressure
15. Oil pressure gearbox
16. Warning lamp, battery charging
17. Warning lamp, battery charging (extra generator)
18. Warning lamp, cab securing system
19. Not connected
20. Marking lights

# F 10 and F 12 Cab

rubber bellows. Furthermore high-frequency noise is prevented from spreading through the lever itself which is in two parts, connected by rubber blocks.

The interior noise level during acceleration at 80 km/hour in top gear is 72-73 dB (A).

**Safety:** The cab satisfies by a wide margin the Swedish safety demands – the most severe in the world. These demands specify that the cab must withstand impact against the windscreen pillar and the rear wall of 29500 Nm (3,000 kpm) and also that the roof must stand up to 15 tons.

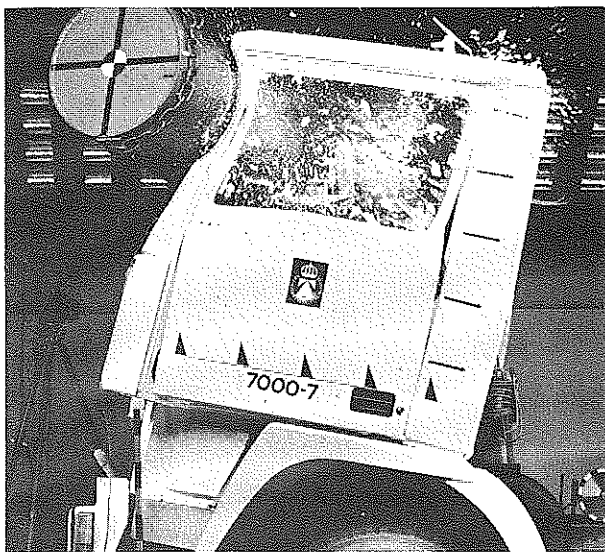

The cab has also been given extra reinforcements level with the driver's knees in the front and also in the form of beams in the doors. The interior equipment is made of fire-resistant material and satisfies the American demands.

All interior sheet-metal surfaces are padded with impact-absorbing material.

Investigations have shown that the steering wheel is often a serious cause of injury in an accident. Therefore, the F 10 and F 12 now feature a steering wheel of special safety design which significantly reduces the risk of injury by deforming under impact.

Three-point seat belts of inertia type are available as optional extras for both the driver and crew seats.

An investigation carried out by Volvo on seat belts and their use gave the following results:

- In 75 % of all accidents, injuries would have been reduced if a three-point seat belt had been used.
- In 5 % of the accidents studied, there would have been a risk of serious injury if a seat belt had been used.
- In 20 % of the accidents studied, the injuries incurred could not be related to whether a seat belt had been used or not.

## SURFACE TREATMENT

The surface treatment process is started by a unique combination of three different **pre-cleaning methods:** Alkalic dip degreasing, brush and spray emulsion degreasing, alkalic spray degreasing. This very thorough cleaning process with the subsequent **zinc phosphating** gives stronger protection against the effects of corrosion such as caused by flying stones or scratches in the paint work, and also provides a good foundation for the following coats of paint.

**Coating no. 1** (EC primer) is applied in a cathodic electro-dip plant. This method, which is entirely superior to previous (anodic) methods, gives above all a better penetration of the paint into body members and cavities.

**Coating no. 2** consists of a special corrosion-resistant spray surfacer which is applied in a heated airless electro static process which results in a thicker coating than conventional spraying methods.

**Coating no. 3** is a sealer coating of paint which increases the total coat thickness and provides an excellent foundation for the 4th and final coating.

**Coating no. 4** is a high-gloss top coat.

**Underbody treatment** consists of a tixotropic rustproofing fluid. The tenacious adhesion and flexible consistency of this rust inhibiting fluid means that any damage or scratches in the surface are healed over.

**Rustproofing treatment** of body members, cavities and joints is provided by a penetrating rust inhibiting fluid.

# F 10 and F 12 Cab

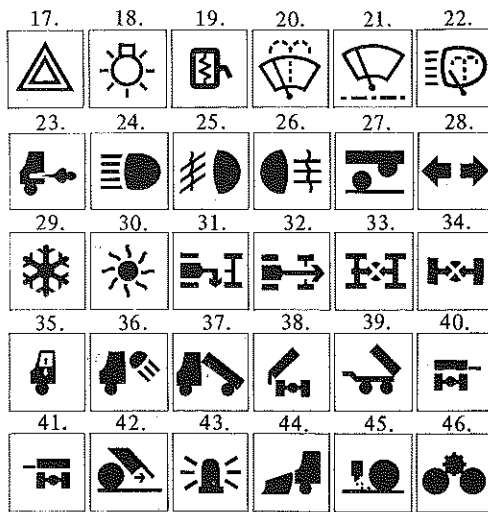

## Symbols for switches

- |  |                                 |
|--|---------------------------------|
| 17. Hazard flashers                    | 32. Power take-off, rear        |
| 18. Headlights and instrument lighting | 33. Differential between axles  |
| 19. Electric rear view mirror          | 34. Differential between wheels |
| 20. Windscreen wipers and washers      | 35. Electric window lift        |
| 21. Intermittent action wipers         | 36. Loading light               |
| 22. Headlight wipers and washers       | 37. Tipper, rear                |
| 23. Exhaust pressure governor          | 38. Tipper, side                |
| 24. Full headlights/Spotlights         | 39. Tipper, trailer             |
| 25. Foglights, front                   | 40. Side wall release, right    |
| 26. Foglights, rear                    | 41. Side wall release, left     |
| 27. Bogie lift                         | 42. Tailboard release           |
| 28. Turn indicators                    | 43. Rotating warning light      |
| 29. Air conditioning system            | 44. Plough                      |
| 30. Engine heater                      | 45. Sanding system              |
| 31. Power take-off, side               | 46. Robson drive                |

**Heating and ventilation.** The cab is fitted with a very effective heating and ventilation system. It is ready to be supplemented with a parking heater. The standard version of the installation is very advanced and incorporates an air conditioning unit. The principle is for warm air to be spread at low velocity through many outlets which are well distributed. Furthermore, the air is aimed so that it warms up surfaces which otherwise would radiate cold.

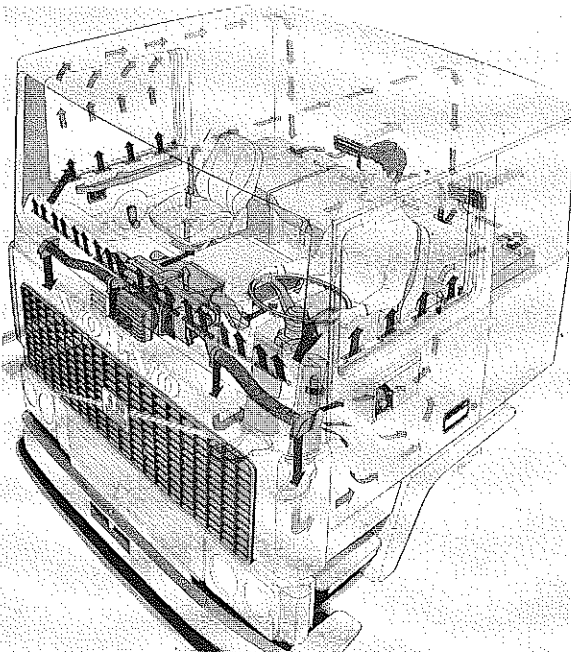

The effect of the heating system makes it possible to maintain a temperature of 35° C inside the cab when outside air temperature is as low as -20° C. The air is cleaned efficiently in a paper filter with an area of 1 m<sup>3</sup> before entering the cab – very important to sufferers of hay fever since all dust and pollen is removed. This filter is cleaned once a month and replaced every year. It is located in an easily accessible position in the cab front.

The capacity of the fan is about 8.5 m<sup>3</sup> of air per minute. The air is spread throughout the cab by means of 24 different nozzles, eight below the windscreen and 4 in each door. Two outlets by the feet of the driver and two by the feet of the passenger, the outermost of which aim air at the side of the doors to prevent cold radiation from the doors. The dashboard includes four nozzles which can be aimed individually or completely closed.

The air leaves the cab through eight openings in the rear edge of the cab. As the picture shows, the air sweeps from the windscreen along the headlining and down the rear wall to the floor. Then the air flows upwards between the wall upholstery and the sheet-metal. Finally the air passes out through openings in the rear cab wall. This system effectively prevents cold radiation from the rear wall, this being particularly important when the cab is to be used for sleeping purposes. Non-return valves prevent the air from going the wrong way through the air outlets. The outlets are dimensioned to maintain a certain excess pressure inside the cab and this prevents draughts from the outside.

The heater system is controlled by means of four levers: temperature, recirculation/fresh air (REC/FRESH), min/max defroster, and min/max floor feed. The REC position is used for extra fast heating or defrosting or to prevent air humidity from becoming too low.

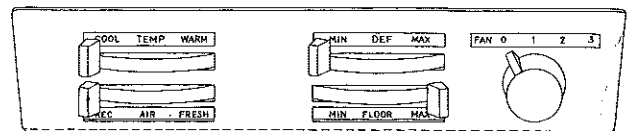

The fan is of the three-speed type. Normally the lowest fan speed, that is to say position 1, is sufficient. The fan should always be switched on for the following reasons:

- Excess pressure in the cab prevents draughts from outside
- It feeds air into the cab even when the truck is being driven very slowly or is standing still
- The thermostat valve cannot function properly if it cannot sense the temperature of the heat exchanger the whole time through the current of air.

# F 10 and F 12 Cab

Position 2 of the fan control does not need to be used until outside air temperature is less than  $-10^{\circ}\text{C}$ . If it is desirable to have maximum heating in the case of very low outside air temperatures, then fan position 2 should be used and not 3. Position 3 is used for rapid de-frosting or fast cooling of the cab (when fitted with air conditioning). The roof hatch makes it possible to keep down the temperature in the cab when the truck is parked.

**Air conditioning:** The air passing through the heating and ventilation system can also be cooled if a version with a built-in cooling system is chosen. The result is then complete air conditioning. When the outside air has a temperature of  $+40^{\circ}\text{C}$ , the air conditioning system can decrease the temperature in the cab by  $10-20^{\circ}\text{C}$  (the efficiency depends on air humidity). In the case of normal outside air temperatures, the cooling possibility can be utilized to dehumidify the air coming in. The air is cooled so that the excess humidity condenses. Heating is then provided through the heater system. The cooling system is connected in by means of a special switch to the left of the heater control panel.

The REC/FRESH control must be in the REC position. The system then takes 80 % of the air from inside the cab, the rest being fresh air from outside.

When the cooling system is being utilized, all the windows and the roof hatch must be closed.

**Parking heater:** (extra equipment). This is built into the heating and ventilation system. The heater consists in principle of a thermostat-controlled oil burner which heats up the engine coolant. The ordinary heating system is then used to heat up the cab.

The heater is switched on and off by means of a thermostat. Since the entire engine cooling system functions as a heat reservoir, it is not necessary to re-start it often as with an air heater when the system is still warm. When the coolant reaches  $50^{\circ}\text{C}$ , the heater fans automatically start up at low speed and blow warm air into the cab. The temperature in the cab is then regulated by means of a special room thermostat which the driver sets. The heater stops when the temperature reaches the set value and starts up again when the temperature has decreased by  $2^{\circ}\text{C}$ . The driver can start up the heater directly or he can set the starting time on a timer.

**Vision:** The cab designer has had to consider two conflicting demands; partly the largest possible glazed area for a wide range of vision, partly the smallest possible glazed area for effective heat insulation. The result is a cab with a large windscreen and large side windows and more effective heater.

The windscreen is kept clean by three windscreen wipers. Windscreen washer nozzles are fitted in each wiper arm. This means that the nozzles follow the movements of the wiper blades, the result being very efficient washing and less wiper blade wear. The windscreen washer has a 16-litre water container.

Close-up vision sideways can be achieved by using a mirror which is available as extra equipment and is located on the upper edge of the passenger door.

## Long cab

The long cab variant is available with one or two bunks. In the one-bunk version, the bunk is located 250 mm higher than the upper surface of the engine casing. This provides two storage areas under the bunk behind the seats with dimensions of  $500 \times 500 \times 600$  mm, one of which is accessible from the outside through a cover in the side of the cab. This cover can only be opened from the inside. Storage can also be carried out under the bunk over the engine housing. In the two-bunk version the lower bunk is located directly over the engine casing, and this naturally decreases storage accommodation. Free height is 550 mm over both bunks.

The long cab has a curtain running on a rail in the roof and this can be pulled over to cover both the side windows and the windscreen.

## Sound insulation

Very extensive measures have been taken concerning sound insulation. The floor and engine casing are covered by heavy bitumen matting,  $8 \text{ kg/m}^2$ . Above this matting there is a carpet consisting of the following layers:

### Engine

- 10 mm spacing material of felt
- a sound-insulating bitumen coating
- a surface coating of soft textile material

### On the floor

- a thin bottom layer of watertight material
- 10 mm spacer material of felt
- a heavy and sound-damping rubber material
- a wear surface of strong rubber.

The walls are covered with sound-absorbing material consisting of textile-covered pressed glass wool.

Many measures have also been taken to prevent sound from penetrating through various cavities.

- The steering column is insulated by means of double rubber bellows.
- Very few cable and piping throughputs.
- The gear lever throughput is fitted with a heavy thick-walled rubber bellows. The visible part of the levers is covered by a "boot" of leather-coloured plastic. Thick felt is fitted between this "boot" and the

# F 10 and F 12 Cab

## Dimensions mm

### External dimensions

Tyres (radials)	11.00R20"	12.00R24"
O. Height (ground-cab roof, unladen)	2950 mm	3013 mm
P. (ground-air intake, unladen)	3310 mm	3346 mm
C. Maximum height, tilted cab with air intake, long cab	3989 mm	4108 mm
Maximum height, tilted cab with air intake, short cab	3692 mm	3811 mm
Maximum height, tilted cab without air intake, long cab -339 short cab -365		
H. Height (ground - first footstep)	474 mm	593 mm
	Short cab	Long cab
E. Length, front axle centre - air intake	470 mm	931 mm
D. Length, bumper-rear wall of cab Overall width 2400 mm	1570 mm	2045 mm
F. Recommended distance air intake - superstructure = 1 cm*		

### Interior dimensions

Floor-roof	1460
Door-door	2170
Height above bunks (2 bunks)	550
Bunk width min.	620
Bunk length	2000
Driving seat: for and-aft adjustment	130
vertical adjustment	65
backrest angle, rearwards	64°

\*Headboard supports can protrude 3 cm from this position.

